

GAS PURGING SYSTEM

- Through the utilization of strong magnets, the Purgemaster always follows the torch.
- Due to the 360° wheels the Purgemaster can be slid sideways and through elbows.
- No need for attaching wires or similar tools to the Purgemaster. Simply slide it out when you are finished welding.
- Through different inserts we cover any available size of pipes from 250mm and up.



DOWNLOAD DXF-FILES FOR YOUR RADIUS DISCS

If you require any further
information or assistance
contact@weldingdroid.com



Weldingdroid ApS
contact@weldingdroid.com
Haandvaerkervej 8
6600 Vejen
Denmark



PURGEMASTER USER MANUAL



WWW.WELDINGDROID.COM

DISTANCE ADJUSTMENT

a) Pay attention to the height of the 360° wheels. The height may affect the Purgemaster gas coverage and the ability of the magnets to hold together. The height is adjusted by screwing the wheels more or less in.

**Interior part shown in illustration.*

This configuration is for pipe welding.

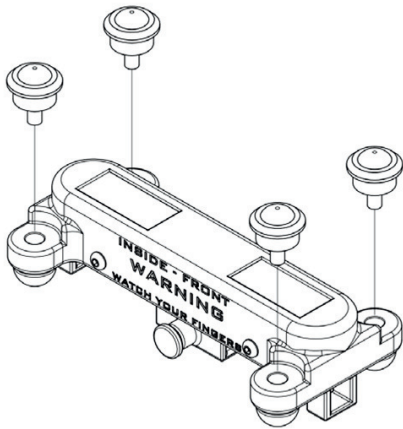

NYLON WHEELS ARE BOLTED TO BRACKETS

b) This is done for both sides, as well as both parts - *Exterior* and *Interior*. In total **4 times**. Note the adjustment holes. Use the holes that get Purgemaster as close to the pipe as possible, but without it touching.

This configuration is for tank welding.

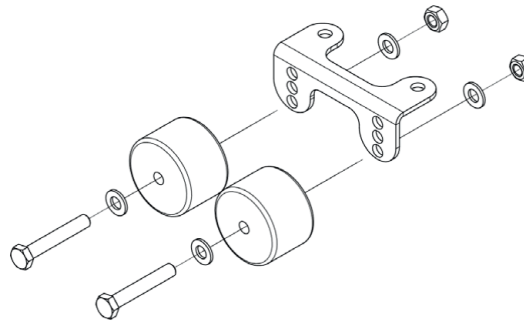

BRACKET WITH NYLON WHEELS SCREWED TO PURGEMASTER

c) Be aware that there is a difference between the inner and outer part. There must be spacers between the bracket and the inner part. See next section for installation on interior part.

**Interior & Exterior part shown in illustration.*

This configuration is for tank welding.

